



# YZ-X9

R i d e   O n  
S c r u b b e r

**Operating Manual**

**Anhui Yangzi Industrial Technology Co., Ltd**

This manual provides the necessary machine operation and maintenance instructions.

**Please read and understand this manual carefully before operating**

Before order replace parts, please kindly check this manual first, please kindly confirm your machine model or SN number.

You can booking parts from authorized dealers or distributor by phone call or email

We will provide best service

\*Be Carefore When You Operation

\*Maintenace the machine by the manual guide

\*Maintenace the machine by manufacturer original parts

# Contents

Notes	3
Notes	4
Machine operation instructions	5
Receiving machine	6
Remove the machine packing	6
Install the battery	6
Machine cleaning mode	7
Brush and clean mat information	7
Machine Installation	7
Install the water suction stripping assembly	7
Install brush / cleaning pad	7
Machine Operation	8
Pre before operation	8
Operating the machine	8
During the machine operation, the	8
Battery power meter	9
Water tank drainage	9
Sewage discharge tank	9
Echarge the clear water tank	9
Battery charging	10
Machine maintenance	10
Daily maintenance	10
Monthly maintenance	11
Maintenance maintenance	12
Handling machine	13
Storage machine	13
Machine parameters	14

## Note

This machine is design used in industrial or commercial ,use on hard floor indoor,can't use in other scenes,strong suggest use clean pad or brush also the clean chemical sales with this machine

All operater must read and understand the safty notice  
Here is the safty notice:

Warning: Used to warn of the risk of serious personal injury or death or unsafe operation.

For safety: Point out the items that must be observed when using the machine to ensure safety.

Failure to observe the following warnings may cause: personal injury, electric shock, fire or explosion.

Warning: Fire or explosion hazard:

-Do not use flammable liquids; do not use flammable liquids, gases or flammable dust near or

Place to operate the machine.

This machine is not equipped with an explosion-proof motor. If in a place with flammable gas, liquid or flammable dust

Using this machine, the electric motor will produce sparks during startup and operation, which may cause flash fire or explosion.

-Do not pick up flammable materials or active metals.

-The battery releases hydrogen. Keep away from sparks or open fire sources

. Keep the battery compartment open when charging.

Warning: Risk of electric shock. Please disconnect the battery wiring before servicing the machine.

Warning: The rotating brush is running. Keep your hands away. Turn off the power before servicing the machine.

The following information points to potentially dangerous situations to operators or equipment:

For safety reasons:

1. Do not operate the machine:

- When in contact with flammable liquid or near flammable gas, whether it may cause an explosion or flash fire situation.
- Unless trained and authorized to operate the machine.
- Unless you have read and understood the operation manual.
- If it is not in the correct operation.

2. Before starting the machine:

- Make sure all safety devices are located and operated correctly

3. When using the machine:

- Please walk slowly when encountering slopes and slippery surfaces.
- Wear non-slip shoes.
- Please slow down when turning.
- If the machine is damaged or the operation fails, it should be reported immediately.
- Do not let children play on or near the machine.
- Follow the mixing ratio and handling instructions on the chemical container.

4. Before leaving or repairing the machine:

- Park the machine on a stable ground.
- Turn off the machine.

5. When servicing the machine:

- Avoid moving parts. Do not wear loose tops, shirts or sleeves.
- Please disconnect the battery wiring before operating the machine.
- Wear protective gloves and eye protection when handling the battery or battery wiring.
- Avoid contact with battery liquid acid.
- Do not use high-pressure spray or water pipe to flush the machine.
- Use replacement parts provided by the manufacturer or approved.
- All maintenance must be carried out by qualified maintenance personnel.
- Do not modify the original design of the machine.

6. When moving the machine:

- Please turn off the machine.
- Do not move the machine when the battery is installed.
- Please move the machine with the assistance of others.
- When loading and unloading machines from trucks or trailers, please use the recommended loading and unloading pads.
- Use ropes to secure the machine to the truck or trailer.
- Lower the brush head to the lowered position.

## Machine operation instructions

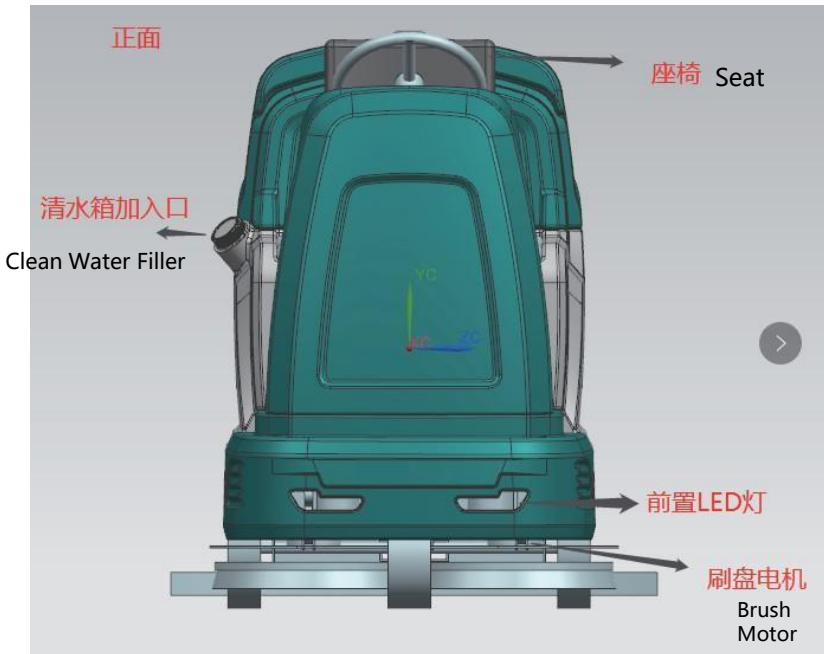
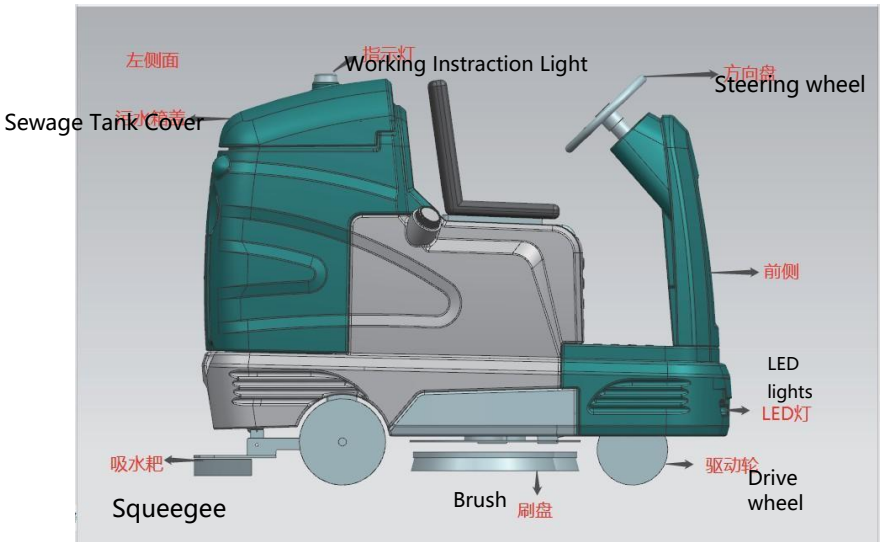

## Receiver-unpack the machine

1. Please check carefully whether there is any damage on the packaging box of the machine. If there is any damage, immediately report to the freight forwarder.
2. Check the shipping content list, if there are any missing items, please contact the seller.

### Freight content:

- \* 6 6V batteries-standard configuration
- \* 1 36V battery charger-standard configuration
- \* 1 set of battery connection cable-standard
- \* 1 pair of absorbent adhesive strips-standard configuration
- \* 2 scrubbing brushes-standard configuration
- \* 2 dials-standard configuration
- \* Other accessories-sold separately

3. Before unpacking the machine, please remove the shipping fixtures and ropes that fix the machine on the warehouse. With the assistance of others, carefully follow

Unload the machine from the warehouse.

Note: If the loading and unloading platform is not used, please do not push the machine directly to avoid damage to the machine.

Note: To avoid damage to the machine, please unload the machine from the warehouse before installing the battery.

## Install the battery

Warning: Risk of fire or explosion. The battery releases hydrogen gas. Keep away from sparks or open fire sources. Keep the battery cover open when charging.

For safety: When servicing the machine, please wear protective gloves and eye protection when handling the battery and battery wiring. Avoid touching the battery

Liquid acid.

1. Park the machine on a level ground and take out the key.
2. Raise the recovery tank to expose the battery compartment
3. Carefully install the battery in the battery compartment gate and connect the battery cable as shown in the figure below

Note: Do not throw the battery into the battery compartment to avoid damage to the battery and the machine.

4. Before connecting the battery, please make sure that the electrodes and terminals are clean. Use electrode cleaning fluid and wire brushes as needed. Note: Apply a thin layer of non-metallic lubricating oil or protective spray to the connected wiring to avoid battery corrosion.
5. After the battery is installed, please check the power scale of the battery power meter. Charge the battery as needed

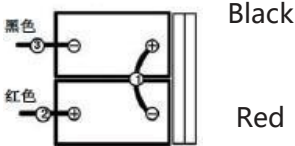

Black

Red

#### Cleaning method:

Manually control the water valve to adjust the amount of cleaning fluid (water and detergent) flowing to the ground. The brush uses a mixture of detergent and water

A suitable solution to clean the floor. While the machine is moving forward, suck the sewage on the floor into the sewage tank with a squeegee.

#### Brush and scouring pad information

To ensure the best performance, please use the correct brush type for cleaning.

Recommended brushes and scouring pads

as follows:

Soft nylon brush (white) -

It is recommended to clean the coated floor without damaging the ground.

Clean without leaving scratches.

Polishing pad (white)-

Used to maintain highly smooth or polished floors.

Cushion pad (red)-

Used to scrub light dirt without hurting the ground.

Gravity discount pad (black)-

Used to forcefully remove heavy coatings or substrates, or for super-powerful scrubbing.



## Machine installation

### Attach the squeegee assembly

1. Park the machine on a level ground and take out the key.
2. Lower the squeegee lift lever to the lower position.
3. Attach the squeegee to the squeegee mounting bracket as shown in the figure. Be sure to completely place the tightening knob into the socket before tightening the knob.
4. Connect the vacuum suction pipe to the squeegee assembly.
5. Check the squeegee rubber strip and make appropriate adjustments

### Install the brush/cleaning pad

Note: For the recommended brushes and scouring pads, please refer to the "Brush and scouring pad information" section of this manual, or Please contact your local authorized dealer.

1. Park the machine on a level ground and take out the key.
2. Step on the brush head lifting pedal to lift the brush head off the ground
3. Put the scouring pad on the needle seat first, and then install the drive disk. Tighten the central lock to fix the scouring pad.
4. Align the needle holder/brush mounting pin with the buckle of the motor drive plate, and press the brush plate motor switch.
5. To remove the needle holder and brush, step on the brush head lifting pedal to lift the brush head off the ground, and press the brush plate motor switch.

## Machine operation

For safety: Do not operate the machine before reading and understanding the operation manual. -

Warning: Risk of fire or explosion. Do not be near or in a place with flammable liquid, gas or flammable dust

Operate the machine.

Check before operation

- Clean the dust on the ground.
- Check the power scale of the battery power meter. (Refer to the battery power meter)
- Check the wear of the pad/brush.
- Check the wear of the squeegee strip and adjust the angle appropriately.
- Make sure that the sewage tank is empty and a clean floating filter has been installed.
- Check the wear of the brush head skirt.

## Operating machine

1. Turn the main power key to (I) position.
2. Pull down the squeegee lift lever to lower the squeegee assembly to the ground.
3. Step on the brush head lifting pedal to lower the brush head to the ground.
4. Turn on the water control knob.
5. Press the switch of the brush plate motor, and then press the switch of the suction motor.
6. Motor-driven model: adjust the speed control knob to the cleaning speed you want

Note: It is recommended to use a cleaning speed of 45-60 meters per minute. During operation of the machine

Warning: Risk of fire or explosion. Do not pick up flammable materials or reactive metals.

1. Each cleaning path overlaps by 5 cm.
2. Keep the machine moving so as not to damage the ground.
3. If there are drag marks on the ground after the squeegee absorbs water, wipe the tape with a rag to remove the garbage. Clean in advance to prevent drag marks.
4. Do not operate the machine on an inclined surface with a slope of more than 5% (3°).

For safety: When using the machine, please move slowly on slopes and slippery surfaces.

5. If there is too much foam, pour the recommended defoamer solution into the recovery tank.

Note: Do not let foam enter the filter to avoid damage to the vacuum motor. Foam will prevent the filter switch from failing

6. Use double cleaning to clean extremely dirty areas. First raise the squeegee for cleaning, let the solution soak for 3-5 minutes

After the clock, lower the squeegee and clean it again.

7. Replace or rotate the pad as needed.
8. Observe the power consumption of the battery power meter (refer to "Battery Power Meter").
9. Check the remaining liquid volume through the clean water tank level gauge. The amount of traditional washing method is about 10 liters per 10 minutes;
10. When the solution in the clean water tank is used up, first empty the recovery tank and then refill the solution.

11. When the staff leave the machine, please park the machine on a level ground and take out the key.
12. After cleaning, perform daily maintenance procedures (refer to "Machine Maintenance").

### Battery gauge

The battery charge gauge will display the battery charge. When the battery is fully charged, all indicator lights are on. As power is consumed, refer to The indicator lights will turn off from right to left. In order to prolong the life of the battery, please do not let the indicator light go out below the following power consumption.

Note: In order to extend the life of the battery, please be sure to charge the battery after the total usage time of the machine exceeds 30 minutes.

### Water tank drainage

The sewage tank should be drained and cleaned after each use. The clean water tank should be cleaned regularly to remove any corroded parts. Transport the machine

Go to the drainage location, turn off the power key, and perform drainage according to the following drainage instructions: For safety: leave or repair the machine

Before, please park the machine on a level ground, turn off the machine and take out the key. Wastewater tank

1. Unscrew the cover of the sewage tank drain pipe counterclockwise and remove it
2. Open the recovery tank cover, and then rinse the water tank
3. Remove and rinse the floating filter located in the sewage tank.

### Battery charging

Note: In order to extend the life of the battery and ensure the best performance of the machine, the machine must be used for at least 30 minutes

Only above can the battery charge. Do not leave the battery uncharged for a long time. The following charging instructions apply to this machine

The included charger. Please be sure to use the charger with the following specifications to avoid battery damage. Battery charger specifications:

- \* Charger type:-Charger for lead-acid battery
- \* Output voltage-36 volts
- \* Output current-25 ampere
- \* Automatic power-off circuit
- \* Suitable for deep cycle battery charging

1. Move the machine to a well-ventilated place for charging.

Warning: Risk of fire or explosion. The battery releases hydrogen gas. Keep away from sparks or open fire sources. Must keep electricity while charging  
The bottle compartment opens.

2. Park the machine on a level ground and turn the key to the off position.

3. Before charging, check the electrolyte level in each battery unit.

For safety: When servicing the machine, please wear protective gloves and eye protection when handling the battery and battery wiring. Avoid contact  
Battery liquid acid.

4. When charging, please open the recovery tank side to facilitate ventilation

5. Plug the AC (alternating current) power cord of the charger into a well-grounded power outlet.

6. Plug the charger's DC (direct current) cable into the battery charging socket behind the recovery tank.

7. The charger will automatically start charging, and will automatically turn off when fully charged.

Note: The machine cannot be operated when the charger is connected. Note: During the charging of the charger, please do not unplug the DC cable of the charger.

Unplug it from the socket on the machine. In order to avoid arc discharge. If you have to suspend charging during charging, please unplug it first  
AC power cord.

Warning: Risk of fire or explosion. The battery releases hydrogen gas. Keep away from sparks or open fire sources. Must keep electricity while charging  
The bottle compartment opens.

8. After charging, check the electrolyte level again.

## Machine maintenance

As long as the daily, weekly and monthly maintenance procedures are followed, the machine can be kept in its best working condition. Warning: Risk of electric shock

risk. Please disconnect the battery wiring before servicing the machine.

### Daily maintenance (after each use)

1. Drain and clean the recovery tank
  2. Remove and rinse the floating filter located in the sewage tank
  3. Drain the clean water tank and flush the tank with hot water not higher than 60°C if necessary
  4. Remove the scouring pad/brush for cleaning. If worn, turn over or replace the scouring pad
  5. Wipe the squeegee rubber strip. Place the squeegee assembly in the raised position to prevent damage to the rubber strip.
  6. Check the wear condition of the squeegee strip blade edge. If it is worn out, swap the two ends of the rubber strip.
  7. Wipe the machine with a multi-purpose cleaner and a damp cloth. For safety: When cleaning the machine, do not use high-pressure spray or water
- Tube flushing machine. So as not to cause malfunction of electronic parts.
8. Check the wear condition of the brush head skirt and replace it if it is worn or damaged.
  9. Charge the battery. In order to prolong the service life of the battery and ensure the best performance of the machine, the machine must be used for longer than

It takes more than 30 minutes to charge the battery.

### Monthly maintenance (every 80 hours of use)

1. Remove the solution tank filter from under the machine and clean the filter screen. Make sure to empty the solution tank before removing the filter.
  2. Clean the top of the battery to prevent electrode corrosion (refer to "Battery Maintenance").
  3. Check whether the battery wiring is loose.
  4. Check and clean the recovery tank cover seal. Replace if damaged.
  5. Spray dry silicone lubricant on all pivots and rollers, and then cover with a layer of waterproof lubricant to keep the axles
- The smooth operation.
6. Check whether the nuts and bolts on the machine are loose.
  7. Check if the machine is leaking.

### Quarterly maintenance

Check the wear of the carbon brushes of the drive motor (drive model), vacuum motor and brush motor every 250 hours. When the length of the carbon brush

When the wear is within 10 mm, the carbon brush needs to be replaced. If the machine needs to be repaired, please contact an authorized service center.

**Warning:** Risk of electric shock. Please disconnect the battery wiring before servicing the machine.

### Handling the machine

When using a truck or trailer to move the machine, be sure to follow the following binding procedures:

1. Raise the brush head to the carrying position.
2. Use the recommended loading dock to load the machine.
3. Place the front of the machine close to the front of the truck or trailer. After the machine is put in place, lower the brush head and turn the key to the off position  
Set.
4. Place obstacles behind each drive wheel to prevent the machine from sliding.
5. Use ropes to secure the top of the machine to prevent tilting. You must install a bracket on the deck of the truck or trailer. For an  
For the sake of all: When moving the machine, please use the recommended loading and unloading platform to load and unload the machine from the truck or trailer, and secure the machine with ropes

On the car board.

### Storage machine

1. Please charge the battery before storing. Do not store when the battery is exhausted.
2. Drain and rinse the tank in the sink thoroughly.
3. Store the machine in a dry place and keep the brush head in the raised position.
4. Open the recovery tank cover to facilitate ventilation. Note: Do not expose the machine to rain and store it indoors.
5. If you store the machine in a cold environment, please make sure to drain all the liquid inside the machine.

## Parameter

Cleaning efficiency	6500m <sup>2</sup> /h
Width of brush plate	567*2mm
width of absorbent steak	1200mm
Rotating speed of brush plate	185rpm
Brush plate motor power	500w*2
Power of suction power	600w
Capacity of clean/sewage tank	240/260L
working hours	6-8h
whole machine weight	535kg
product size	1850*1200*1500

